

SECTION **FSU**
FRONT SUSPENSION

A
B
C
D
F
G
H
I
J
K
L
M
N
O
P

FSU

CONTENTS

PRECAUTION	2	Disposal	11
PRECAUTIONS	2	TRANSVERSE LINK	13
Precaution for Supplemental Restraint System (SRS) "AIR BAG" and "SEAT BELT PRE-TENSIONER"	2	Exploded View	13
Precautions for Suspension	2	Removal and Installation	13
PREPARATION	3	FRONT STABILIZER	15
PREPARATION	3	Exploded View	15
Special Service Tool	3	Removal and Installation	15
Commercial Service Tool	4	STEERING KNUCKLE	17
SYMPTOM DIAGNOSIS	5	Exploded View	17
NOISE, VIBRATION AND HARSHNESS (NVH) TROUBLESHOOTING	5	Removal and Installation	17
NVH Troubleshooting Chart	5	UNIT REMOVAL AND INSTALLATION	18
PERIODIC MAINTENANCE	6	FRONT SUSPENSION MEMBER	18
FRONT SUSPENSION ASSEMBLY	6	Exploded View	18
Inspection	6	Removal and Installation	18
WHEEL ALIGNMENT	7	UNIT DISASSEMBLY AND ASSEMBLY ...	19
Inspection	7	FRONT COIL SPRING AND STRUT	19
Adjustment	8	Exploded View	19
REMOVAL AND INSTALLATION	10	Disassembly and Assembly	19
FRONT COIL SPRING AND STRUT	10	SERVICE DATA AND SPECIFICATIONS (SDS)	23
Exploded View	10	SERVICE DATA AND SPECIFICATIONS (SDS)	23
Removal and Installation	10	Wheel Alignment (Unladen*)	23
		Ball Joint	24
		Wheelarch Height (Unladen* ¹)	24

PRECAUTIONS

< PRECAUTION >

PRECAUTION

PRECAUTIONS

Precaution for Supplemental Restraint System (SRS) "AIR BAG" and "SEAT BELT PRE-TENSIONER"

INFOID:000000012262353

The Supplemental Restraint System such as "AIR BAG" and "SEAT BELT PRE-TENSIONER", used along with a front seat belt, helps to reduce the risk or severity of injury to the driver and front passenger for certain types of collision. Information necessary to service the system safely is included in the SR and SB section of this Service Manual.

WARNING:

- To avoid rendering the SRS inoperative, which could increase the risk of personal injury or death in the event of a collision which would result in air bag inflation, all maintenance must be performed by an authorized NISSAN/INFINITI dealer.
- Improper maintenance, including incorrect removal and installation of the SRS, can lead to personal injury caused by unintentional activation of the system. For removal of Spiral Cable and Air Bag Module, see the SR section.
- Do not use electrical test equipment on any circuit related to the SRS unless instructed to in this Service Manual. SRS wiring harnesses can be identified by yellow and/or orange harnesses or harness connectors.

PRECAUTIONS WHEN USING POWER TOOLS (AIR OR ELECTRIC) AND HAMMERS

WARNING:

- When working near the Airbag Diagnosis Sensor Unit or other Airbag System sensors with the Ignition ON or engine running, DO NOT use air or electric power tools or strike near the sensor(s) with a hammer. Heavy vibration could activate the sensor(s) and deploy the air bag(s), possibly causing serious injury.
- When using air or electric power tools or hammers, always switch the Ignition OFF, disconnect the battery and wait at least three minutes before performing any service.

Precautions for Suspension

INFOID:000000012262352

- When installing rubber bushings, the final tightening must be carried out under unladen conditions with tires on ground. Spilled oil might shorten the life of rubber bushings. Be sure to wipe off any spilled oil.
- Unladen conditions mean that fuel, engine coolant and lubricants are full. Spare tire, jack, hand tools and mats are in designated positions.
- After servicing suspension parts, be sure to check wheel alignment.
- Self-lock nuts are not reusable. Always use new ones when installing. Since new self-lock nuts are pre-oiled, tighten as they are.

PREPARATION

< PREPARATION >

PREPARATION

PREPARATION

Special Service Tool

INFOID:000000011935657

The actual shape of the tools may differ from those illustrated here.

Tool number (TechMate No.) Tool name	Description
ST35652000 (—) Strut attachment	Securing strut outer tube in a vise while disassembling and assembling front coil spring and strut.
— (J-44372) Spring gauge	Measuring ball joint swinging force.
— (J-49286) Drift and Pull gauge	Measuring drift and pull
— (J-49029) Strut rod clamp	Securing strut rod while disassembling and assembling front coil spring and strut.

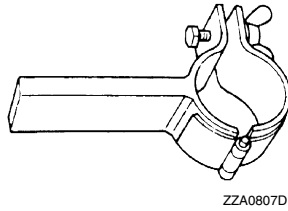

ZZA0807D

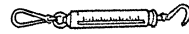

LST024

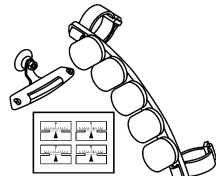

AWEIA0156ZZ

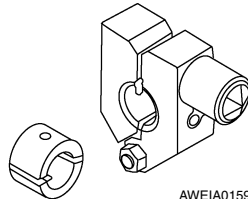

AWEIA0159ZZ

A
B
C
D
E
F
G
H
I
J
K
L
M
N
O
P

FSU

PREPARATION

< PREPARATION >

Commercial Service Tool

INFOID:000000011935658

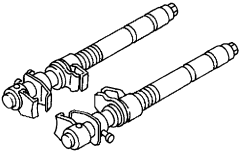
Tool name	Description
<p data-bbox="162 289 272 315">Power tool</p>  <p data-bbox="863 506 932 525">PIIB1407E</p>	<p data-bbox="1057 289 1393 315">Loosening nuts, screws and bolts</p>
<p data-bbox="162 541 354 567">Spring compressor</p>  <p data-bbox="863 758 909 777">NT717</p>	<p data-bbox="1057 541 1406 567">Removing and installing coil spring</p>

NOISE, VIBRATION AND HARSHNESS (NVH) TROUBLESHOOTING

< SYMPTOM DIAGNOSIS >

SYMPTOM DIAGNOSIS

NOISE, VIBRATION AND HARSHNESS (NVH) TROUBLESHOOTING

NVH Troubleshooting Chart

INFOID:000000011935659

Use the chart below to help you find the cause of the symptom. If necessary, repair or replace these parts.

Reference page		FSU-10	FSU-13	FSU-19	—	—	FSU-24	FSU-18	FSU-23	FSU-15	WT-62	WT-62	FAX-5	BR-6	ST-28
Possible cause and SUSPECTED PARTS		Improper installation, looseness	Shock absorber deformation, damage or deflection	Bushing or mounting deterioration	Parts interference	Spring fatigue	Suspension looseness	Incorrect wheel alignment	Stabilizer bar fatigue	TIRE	WHEEL	DRIVE SHAFT	BRAKES	STEERING	
Symptom	Noise	x	x	x	x	x	x			x	x	x	x	x	x
	Shake	x	x	x	x		x			x	x	x	x	x	x
	Vibration	x	x	x	x	x				x		x			x
	Shimmy	x	x	x	x			x		x	x		x	x	x
	Shudder	x	x	x						x	x		x	x	x
	Poor quality ride or handling	x	x	x	x	x	x		x	x	x	x			

x: Applicable

A
B
C
D
E
F
G
H
I
J
K
L
M
N
O
P

FSU

FRONT SUSPENSION ASSEMBLY

< PERIODIC MAINTENANCE >

PERIODIC MAINTENANCE

FRONT SUSPENSION ASSEMBLY

Inspection

INFOID:0000000012273845

ON-VEHICLE SERVICE

- Check the suspension parts for excessive play, cracks, wear or damage. Shake each front wheel to check for excessive play.
- Retighten all nuts and bolts to the specified torque.
- Make sure that each cotter pin is installed.
- Check the wheelarch height. Refer to [FSU-24. "Wheelarch Height \(Unladen*1\)"](#).

INSPECTION

Check the conditions (looseness, backlash) of each component. Verify that component conditions (wear, damage) are normal.

FRONT COIL SPRING AND STRUT

Check for oil leakage and damage. Replace parts if necessary.

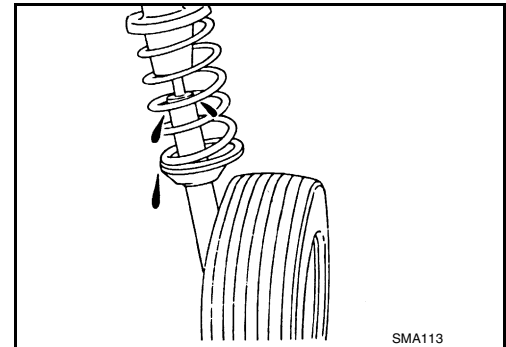

TRANSVERSE LINK

- Check the transverse link for damage, cracks, or deformation and replace if necessary.
- Check the rubber bushings for damage, cracks or deformation. Replace transverse link if necessary.
- Check the ball joint for grease leaks and the ball joint dust cover for cracks or other damage.
- Check the ball joint. Replace the suspension arm if the ball stud is worn or the joint is hard to swing.

FRONT STABILIZER

- Check the front stabilizer and clamps for any deformation, cracks or damage and replace if necessary.
- Check the rubber bushings for deterioration or cracks and replace if necessary.

STEERING KNUCKLE

Check the steering knuckle for any deformation, cracks, or other damage and replace if necessary.

WHEEL ALIGNMENT

< PERIODIC MAINTENANCE >

WHEEL ALIGNMENT

Inspection

INFOID:000000012271813

PRELIMINARY INSPECTION

WARNING:

Always adjust wheel alignment with vehicle on a flat surface.

NOTE:

If wheel alignment is out of specification, inspect and replace any damaged or worn suspension parts before making any adjustments.

Check the following:

- Check and adjust wheel alignment with vehicle under unladen conditions. "Unladen conditions" means that fuel, engine coolant, and lubricants are full; spare tire, jack, hand tools and mats are in designated positions.
- Check tires for incorrect air pressure and excessive wear. Refer to [WT-73, "Tire"](#).
- Check wheels for deformation, cracks, and other damage. Remove wheel and check wheel runout. Refer to [WT-63, "Inspection"](#).
- Check wheel bearing axial end play. Refer to [FAX-6, "Inspection"](#).
- Check struts for leaks or damage.
- Check each mounting point of suspension components for any excessive looseness or damage.
- Check each link, arm, and suspension member for any damage.
- Check wheelarch height in unladen conditions. Refer to [FSU-24, "Wheelarch Height \(Unladen*1\)"](#).

GENERAL INFORMATION AND RECOMMENDATIONS

1. A four-wheel thrust alignment should be performed.
 - This type of alignment is recommended for any NISSAN/INFINITI vehicle.
 - The four-wheel "thrust" process helps ensure that the vehicle is properly aligned and the steering wheel is centered.
 - The alignment machine itself should be capable of accepting any NISSAN/INFINITI vehicle.
 - The alignment machine should be checked to ensure that it is level.
2. Make sure the machine is properly calibrated.
 - Your alignment equipment should be regularly calibrated in order to give correct information.
 - Check with the manufacturer of your specific alignment machine for their recommended Service/Calibration Schedule.

ALIGNMENT PROCESS

CAUTION:

If the vehicle is equipped with the Intelligent Cruise Control (ICC) system and the rear toe has been adjusted during a wheel alignment, the ICC sensor must be aligned. Refer to [CCS-64, "ICC Sensor Adjustment"](#).

IMPORTANT:

Use only the alignment specifications listed in this Service Manual. Refer to [FSU-23, "Wheel Alignment \(Unladen*\)"](#).

1. When displaying the alignment settings, many alignment machines use "indicators": (Green/red, plus or minus, Go/No Go.) **Do not use these indicators.**
 - The alignment specifications programmed into your alignment machine that operate these indicators may not be correct.
 - This may result in an ERROR.
2. Most camera-type alignment machines are equipped with both a "Rolling Compensation" method and an optional "Jacking Compensation" method to compensate the alignment targets or head units. "Rolling Compensation" is the preferred method.
 - If using the "Rolling Compensation" method, after installing the alignment targets or head units, push or pull on the rear wheel to move the vehicle. **Do not push or pull on the vehicle body.**
 - If using the "Jacking Compensation" method, after installing the alignment targets or head units, raise the vehicle and rotate the wheels 1/2 turn both ways.

NOTE:

- Do not use the "Rolling Compensation" method if you are using sensor-type alignment equipment.
- Follow all instructions for the alignment machine you are using for more information.

CAMBER, CASTER AND KINGPIN INCLINATION ANGLE INSPECTION

CAUTION:

A

B

C

D

FSU

F

G

H

I

J

K

L

M

N

O

P

WHEEL ALIGNMENT

< PERIODIC MAINTENANCE >

Camber, caster, kingpin inclination angles cannot be adjusted.

Before inspection, set front wheels onto a turning radius gauge. Set rear wheels onto a pad that has the same height so vehicle will remain horizontal.

TOTAL TOE-IN INSPECTION

Measure total toe-in using following procedure:

WARNING:

- Always perform following procedure on a flat surface.
- Make sure that no person is in front of vehicle before pushing it.

1. Bounce front of vehicle up and down to stabilize vehicle height (posture).
2. Push on rear wheel to move vehicle straight ahead about 5 m (16 ft).
3. Put a mark on base line of tread (rear side) of both tires at same height as hub center. These are measuring points.

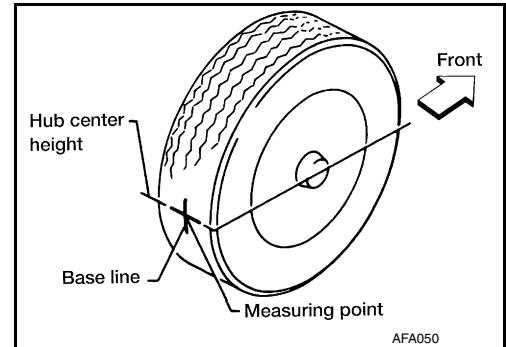

4. Measure distance (A) from rear side.
5. Push on rear wheel to move vehicle slowly ahead to rotate the wheels 180 degrees (1/2 turn).

CAUTION:

If wheels have rotated more than 180 degrees (1/2 turn), try above procedure again from beginning. Do not push vehicle backward.

6. Measure distance (B) from front side.

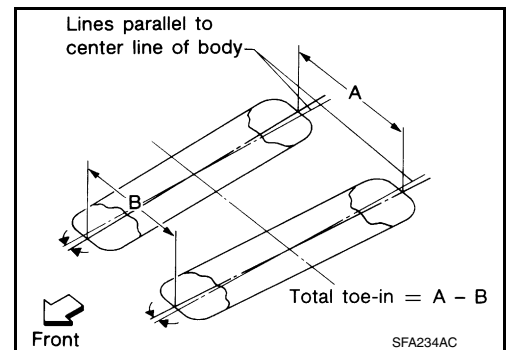

7. Use formula below to calculate total toe-in.

Total toe-in formula : $A - B$

Total toe-in specification : Refer to [FSU-23, "Wheel Alignment \(Unladen*\)"](#).

- If total toe-in is outside specification, adjust total toe-in. Refer to [FSU-8, "Adjustment"](#).

Adjustment

INFOID:000000012271814

TOE-IN ADJUSTMENT

1. Loosen inner socket lock nut (A).

CAUTION:

To prevent damage, hold outer socket (1) across flats using suitable tool while loosening inner socket lock nut.

2. Adjust toe using the inner socket.

CAUTION:

Always evenly adjust toe using LH and RH inner sockets alternately and adjust total toe-in to the standard.

Total toe-in : Refer to [FSU-23, "Wheel Alignment \(Unladen*\)"](#).

3. Tighten inner socket lock nut. Refer to [ST-39, "Exploded View"](#).

CAUTION:

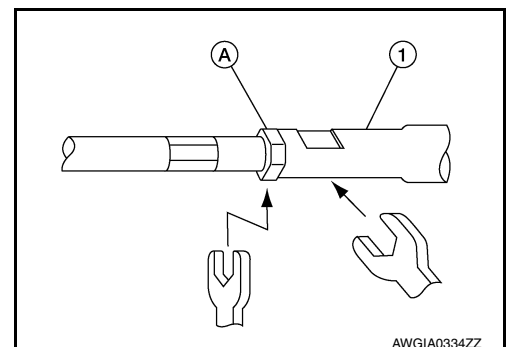

WHEEL ALIGNMENT

< PERIODIC MAINTENANCE >

- To prevent damage, hold outer socket across flats using suitable tool while tightening inner socket lock nut.
 - Inspect to make sure no boot deformation has occurred during toe-in adjustment. Adjust boot as necessary.
 - If vehicle is equipped with Intelligent Cruise Control (ICC) system and rear toe has been adjusted during a wheel alignment, the ICC sensor must be aligned. Refer to [CCS-64, "ICC Sensor Adjustment"](#).
4. After toe-in adjustment, adjust neutral position of steering angle sensor. Refer to [BRC-64, "Description"](#) (without ICC) [BRC-248, "Description"](#) (with ICC).

A

B

C

D

FSU

F

G

H

I

J

K

L

M

N

O

P

FRONT COIL SPRING AND STRUT

< REMOVAL AND INSTALLATION >

REMOVAL AND INSTALLATION

FRONT COIL SPRING AND STRUT

Exploded View

INFOID:0000000012242622

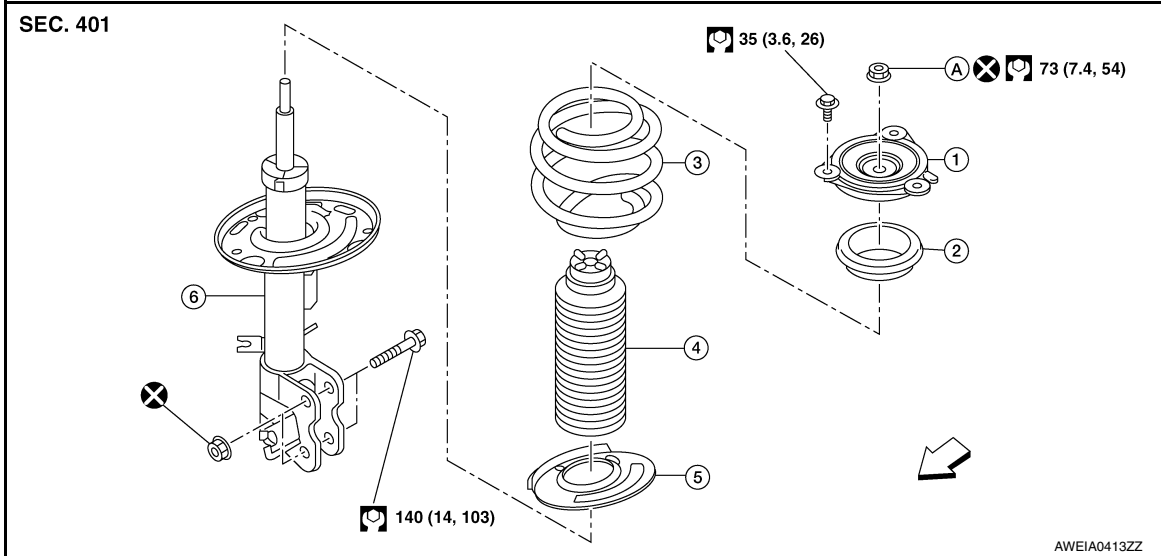

- | | | |
|--------------------------|----------------------|----------------------|
| 1. Strut mount insulator | 2. Upper rubber seat | 3. Front coil spring |
| 4. Bound bumper | 5. Lower rubber seat | 6. Strut |
| A. Piston rod lock nut | ⇐ Front | |

Removal and Installation

INFOID:0000000011935661

REMOVAL

1. Remove wheel and tire using power tool. Refer to [WT-67, "Exploded View"](#).
2. Separate front wheel sensor harness from front coil spring and strut.
3. Remove brake hose lock plate (A).

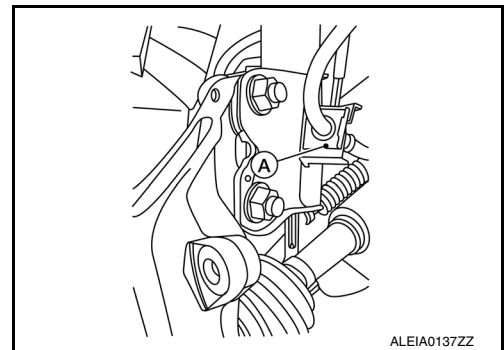

4. Remove stabilizer connecting rod nut (A) from front coil spring and strut. Position stabilizer connecting rod aside. Refer to [FSU-15, "Exploded View"](#).

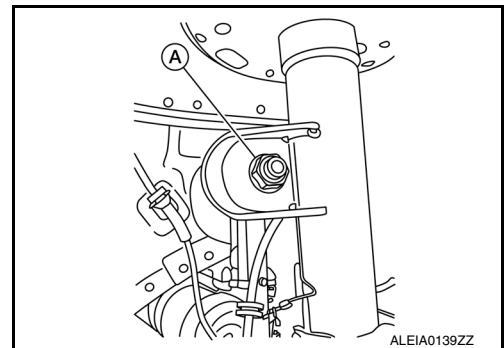

FRONT COIL SPRING AND STRUT

< REMOVAL AND INSTALLATION >

5. Remove lower strut nuts and bolts using power tool.
6. Remove bolts on strut tower.
7. Remove front coil spring and strut.

INSPECTION AFTER REMOVAL

Strut

Check following items, and replace strut if necessary:

- Strut for deformation, cracks or damage
- Piston rod for damage, uneven wear or distortion
- Oil leakage

Strut Mount Insulator, Strut Mount Bearing, and Rubber Parts

Check following items, and replace parts if necessary:

- Strut mount insulator and strut mount bearing for cracks
- Rubber parts for wear

Front Coil Spring

Check front coil spring for cracks, wear, or damage. Replace front coil spring if necessary.

INSTALLATION

Installation is in the reverse order of removal.

CAUTION:

Do not reuse lower strut nuts.

- Be sure tab (A) on strut mount insulator is positioned as shown.

← : Front

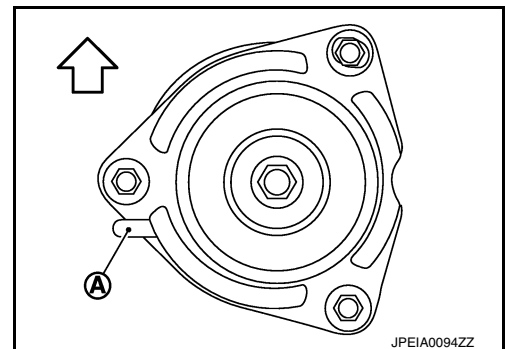

- Be sure lower strut nuts (A) are facing front of vehicle.

← : Front

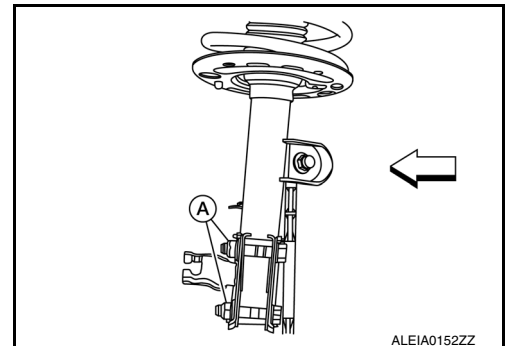

- Check wheel alignment. Refer to [FSU-7, "Inspection"](#).
- Adjust neutral position of steering angle sensor. Refer to [BRC-64, "Description"](#) (without ICC) [BRC-248, "Description"](#) (with ICC).
- After replacing strut, follow disposal procedure to discard old strut. Refer to [FSU-11, "Disposal"](#).

Disposal

INFOID:000000012250380

1. Set strut horizontally with piston rod fully extended.

A
B
C
D
FSU
F
G
H
I
J
K
L
M
N
O
P

FRONT COIL SPRING AND STRUT

< REMOVAL AND INSTALLATION >

2. Drill a 2 – 3 mm (0.08 – 0.12 in) hole at position (●) from top as shown to release gas gradually.

CAUTION:

- Wear eye protection (safety glasses).
- Wear gloves.
- Be careful with metal chips or oil blown out by compressed gas.

NOTE:

- Drill vertically in this direction (←) directly into outer tube avoiding brackets.
- The gas is clear, colorless, odorless, and harmless.

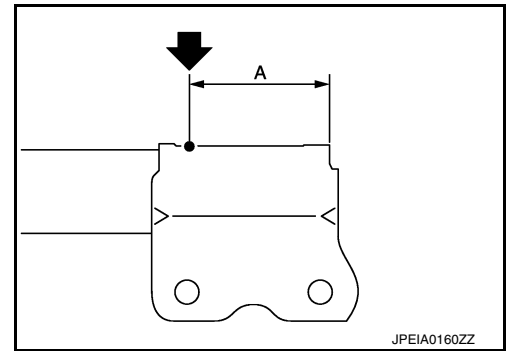

(A) : 20 – 30 mm (0.79 – 1.18 in)

3. Position drilled hole downward and drain oil by moving piston rod several times.

CAUTION:

Dispose of drained oil according to the law and local regulations.

TRANSVERSE LINK

< REMOVAL AND INSTALLATION >

TRANSVERSE LINK

Exploded View

INFOID:000000012242623

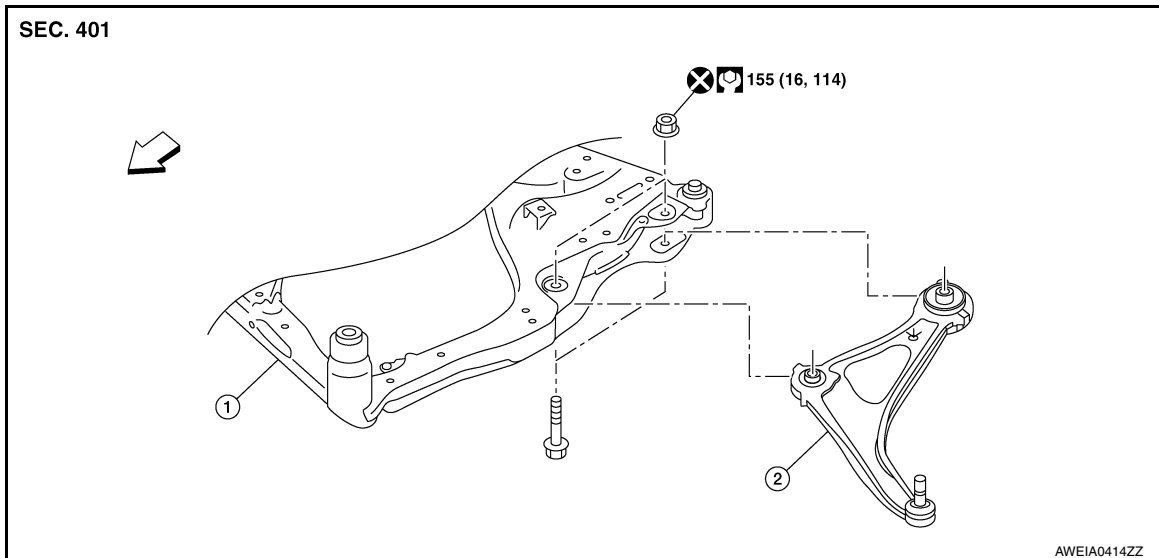

1. Transverse link

2. Front suspension member

← Front

Removal and Installation

INFOID:000000011935663

REMOVAL

1. Remove front disc brake rotor. Refer to [BR-41, "DISC BRAKE ROTOR : Removal and Installation"](#).

2. Remove front wheel sensor bolt (A) and front wheel sensor from steering knuckle. Refer to [BRC-164, "FRONT WHEEL SENSOR : Removal and Installation"](#).

CAUTION:

- Failure to separate front wheel sensor from steering knuckle may result in damage to front wheel sensor.
- Pull out front wheel sensor being careful to turn it as little as possible. Do not pull on wheel sensor harness.

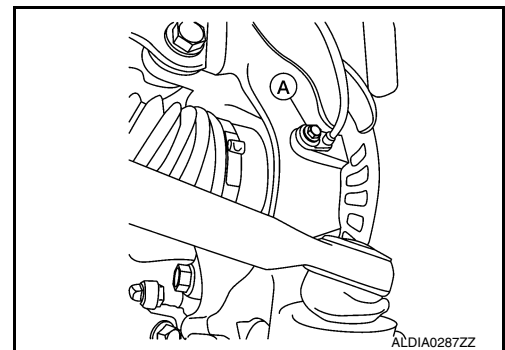

3. Remove cotter pin.

4. Remove nut retainer.

5. Loosen wheel hub lock nut from drive shaft using power tool.

6. Using a piece of wood and suitable tool, tap on wheel hub lock nut to disengage drive shaft from wheel hub and bearing.

CAUTION:

- Do not place drive shaft joint to an extreme angle. Also be careful not to overextend slide joint.
- Do not allow drive shaft to hang down without support.

NOTE:

Use suitable puller if drive shaft cannot be separated from wheel hub and bearing.

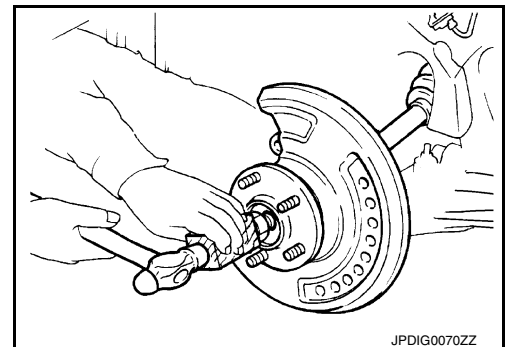

7. Remove wheel hub lock nut.

A
B
C
D
FSU
F
G
H
I
J
K
L
M
N
O
P

TRANSVERSE LINK

< REMOVAL AND INSTALLATION >

8. Remove cotter pin from outer socket stud.
9. Loosen outer socket nut and separate outer socket from steering knuckle using suitable tool.
CAUTION:
Leave outer socket nut half threaded on outer socket to prevent damage to threads and to prevent suitable tool from coming off suddenly.
10. Remove outer socket nut and separate outer socket from steering knuckle. Refer to [ST-39, "Exploded View"](#).
11. Remove front strut bolts at steering knuckle. Refer to [FSU-10, "Exploded View"](#).
12. Remove steering knuckle lower pinch bolt and nut and separate transverse link from steering knuckle. Refer to [FSU-17, "Exploded View"](#).
13. Remove steering knuckle.
14. Remove transverse link nuts and bolts at front suspension member.
15. Remove transverse link from front suspension member.

INSPECTION AFTER REMOVAL

Ball Joint Inspection

Manually move ball joint to confirm it moves smoothly with no binding.

Swinging Torque Inspection

1. Move ball joint at least ten times by hand to check for smooth movement.
2. Hook Tool (A) on ball joint at pinch bolt location. Confirm measurement value is within specification when ball joint begins moving.

Tool number : - (J-44372)

Swinging torque : Refer to [FSU-24, "Ball Joint"](#).

- If swinging torque exceeds standard range, replace transverse link.

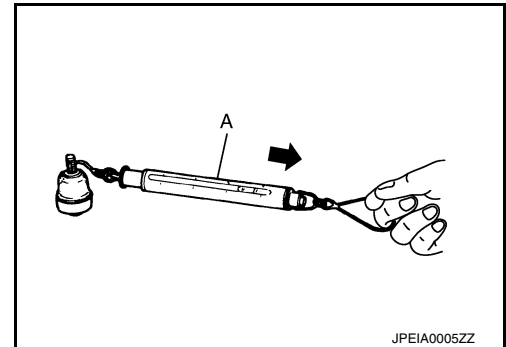

Rotating Torque Inspection

1. Move ball joint at least ten times by hand to check for smooth movement.
2. Confirm measurement value is within specification when ball joint begins rotating.

Rotating torque : Refer to [FSU-24, "Ball Joint"](#).

- If rotating torque exceeds standard range, replace transverse link.

Axial End Play Inspection

1. Move ball joint at least ten times by hand to check for smooth movement.
2. Move tip of ball joint in axial direction to check for looseness.

Axial end play : Refer to [FSU-24, "Ball Joint"](#).

- If axial end play exceeds standard value, replace transverse link.

INSTALLATION

Installation is in the reverse order of removal.

CAUTION:

Do not reuse transverse link nuts at front suspension member.

- Perform final tightening of bolts and nuts at front suspension member under unladen conditions with tires on level ground.
- Check wheel alignment. Refer to [FSU-7, "Inspection"](#).
- Adjust neutral position of steering angle sensor. Refer to [BRC-64, "Description"](#).

FRONT STABILIZER

< REMOVAL AND INSTALLATION >

FRONT STABILIZER

Exploded View

INFOID:000000012242624

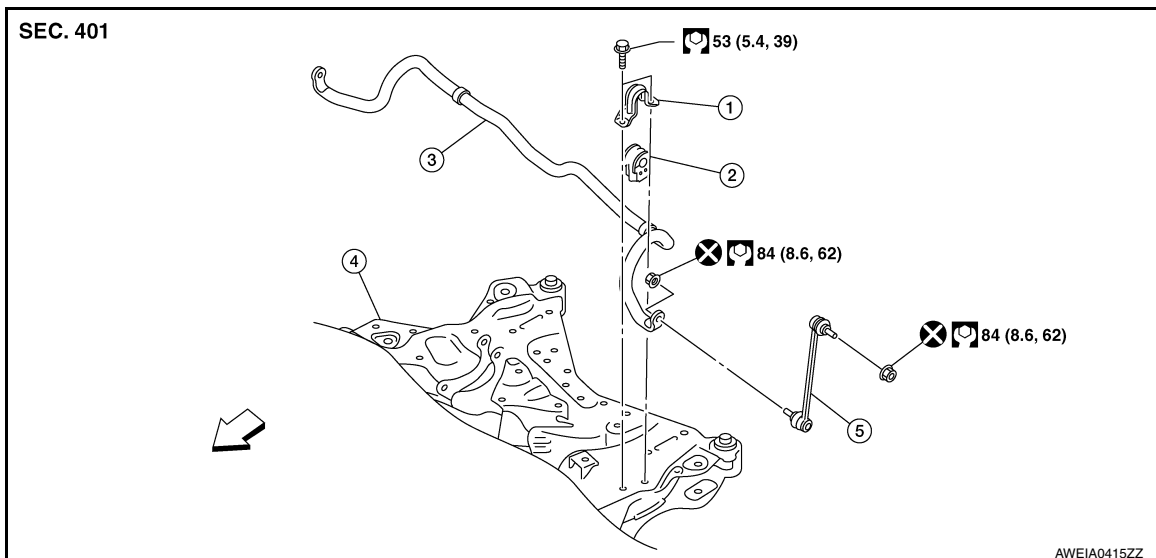

- 1. Stabilizer clamp
 - 2. Stabilizer bushing
 - 3. Stabilizer
 - 4. Front suspension member
 - 5. Stabilizer connecting rod
- ← Front

Removal and Installation

INFOID:000000011935664

REMOVAL

1. Remove front undercover. Refer to [EXT-26, "Removal and Installation"](#).
2. Remove each stabilizer connecting rod nut (A) at stabilizer bar.

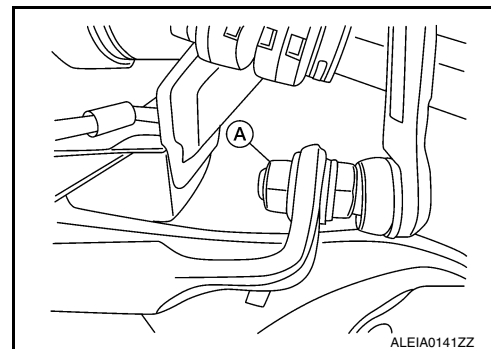

3. Remove power steering gear. Refer to [ST-48, "Removal and Installation"](#).
4. Remove bolts (←) from stabilizer clamps, and then remove stabilizer clamps and stabilizer bushings from front suspension member.

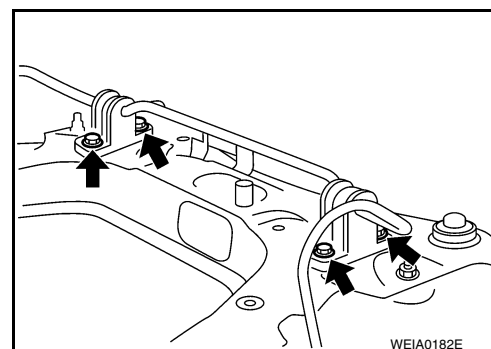

5. Remove stabilizer from the vehicle.

INSPECTION AFTER REMOVAL

A
B
C
D
FSU
F
G
H
I
J
K
L
M
N
O
P

FRONT STABILIZER

< REMOVAL AND INSTALLATION >

Check stabilizer, stabilizer connecting rod, stabilizer bushing, and stabilizer clamp for deformation, cracks and damage. Replace if necessary.

INSTALLATION

Installation is in the reverse order of removal. Refer to [FSU-18, "Exploded View"](#).

- When installing stabilizer, make sure that notch (A) in stabilizer clamps face front.
- Make sure each slit (B) in surface of each stabilizer bushing faces rear of the vehicle.

← :Front

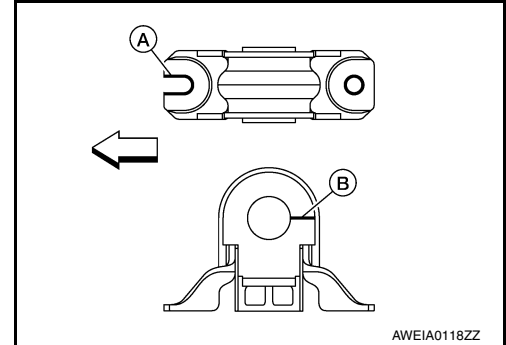

- The stabilizer uses a pillow ball type stabilizer connecting rod. Position ball joint with case on pillow ball head parallel to stabilizer.

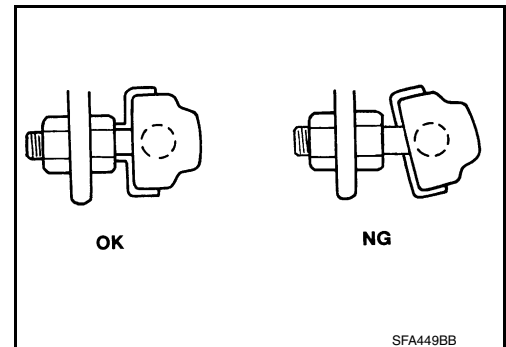

STEERING KNUCKLE

< REMOVAL AND INSTALLATION >

STEERING KNUCKLE

Exploded View

INFOID:0000000112242625

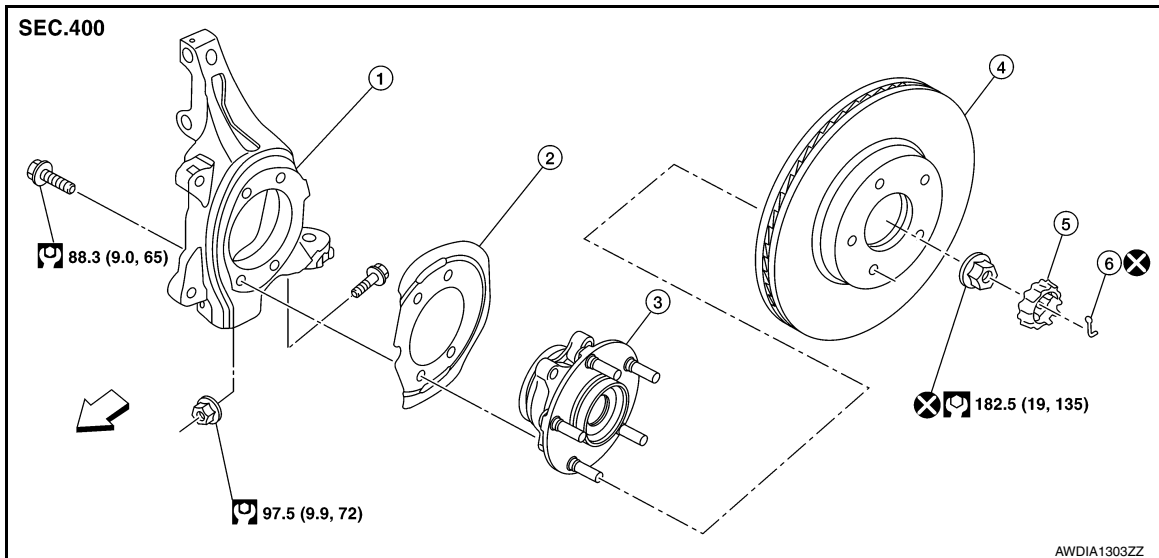

- | | | |
|---------------------|-----------------|--------------------------|
| 1. Steering knuckle | 2. Splash guard | 3. Wheel hub and bearing |
| 4. Disc brake rotor | 5. Nut retainer | 6. Cotter pin |
- ← Front

Removal and Installation

INFOID:000000011935665

REMOVAL

1. Remove front wheel hub and bearing. Refer to [FAX-8, "Removal and Installation"](#).
2. Remove cotter pin from outer socket stud.
3. Loosen outer socket nut and separate outer socket from steering knuckle using suitable tool.
CAUTION:
Leave outer socket nut half threaded on outer socket to prevent damage to threads and to prevent suitable tool from coming off suddenly.
4. Remove outer socket nut and separate outer socket from steering knuckle. Refer to [ST-39, "Exploded View"](#).
5. Remove front strut bolts at steering knuckle. Refer to [FSU-10, "Exploded View"](#).
6. Remove steering knuckle lower pinch bolt and nut and separate transverse link from steering knuckle.
7. Remove steering knuckle.

INSPECTION AFTER REMOVAL

Check for deformity, cracks and damage on each part. Replace if necessary.

INSTALLATION

Installation is in the reverse order of removal.

CAUTION:

- Do not reuse cotter pin.
- Do not reuse wheel hub lock nut.
- Do not use a power tool to tighten the wheel hub lock nut.
- Check wheel alignment. Refer to [FSU-7, "Inspection"](#).
- Adjust neutral position of steering angle sensor. Refer to [BRC-64, "Description"](#).

FRONT SUSPENSION MEMBER

< UNIT REMOVAL AND INSTALLATION >

UNIT REMOVAL AND INSTALLATION

FRONT SUSPENSION MEMBER

Exploded View

INFOID:000000011935666

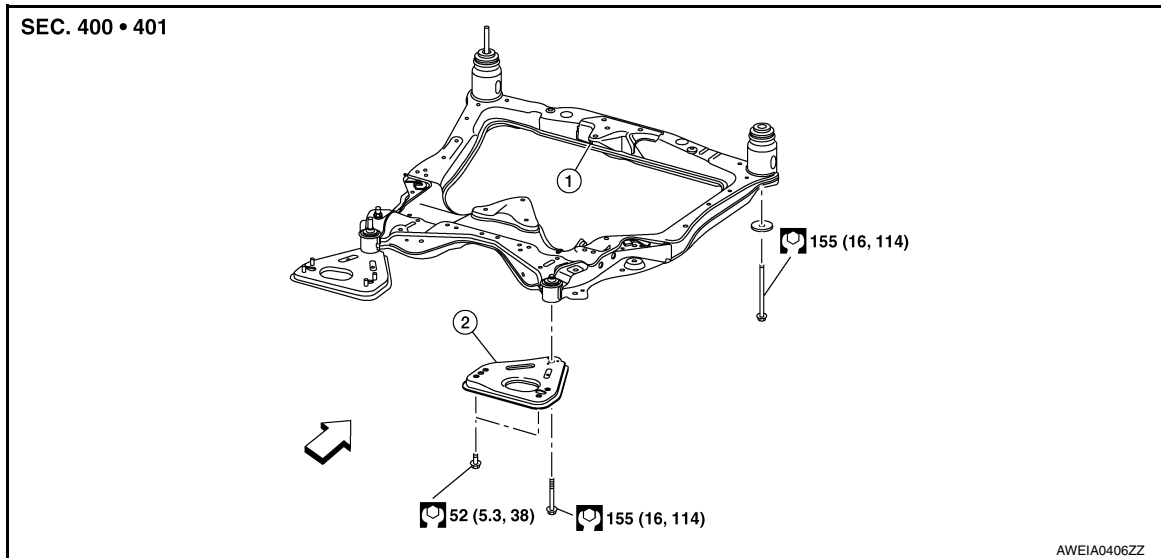

1. Front suspension member 2. Front suspension member stay ← Front

Removal and Installation

INFOID:000000011935667

REMOVAL

1. Remove engine and transmission with front suspension member. Lift engine and transmission off suspension member. Refer to [EM-107, "Removal and Installation"](#).

NOTE:

Engine, transmission and suspension member must be removed as an assembly.

2. If necessary, remove steering knuckles. Refer to [FSU-17, "Exploded View"](#).
3. If necessary, remove transverse links. Refer to [FSU-13, "Exploded View"](#).
4. If necessary, remove stabilizer. Refer to [FSU-15, "Exploded View"](#).
5. If necessary, remove steering gear and hydraulic lines. Refer to [ST-39, "Exploded View"](#).

INSPECTION AFTER REMOVAL

Check front suspension member for significant deformation, cracks, or damages. Replace if necessary.

INSTALLATION

Installation is in the reverse order of removal.

- After installation, perform final tightening of each part under unladen conditions with tires on level ground.
- Check wheel alignment. Refer to [FSU-7, "Inspection"](#).
- Adjust neutral position of the steering angle sensor. Refer to [BRC-64, "Description"](#).

FRONT COIL SPRING AND STRUT

< UNIT DISASSEMBLY AND ASSEMBLY >

UNIT DISASSEMBLY AND ASSEMBLY

FRONT COIL SPRING AND STRUT

Exploded View

INFOID:000000012242626

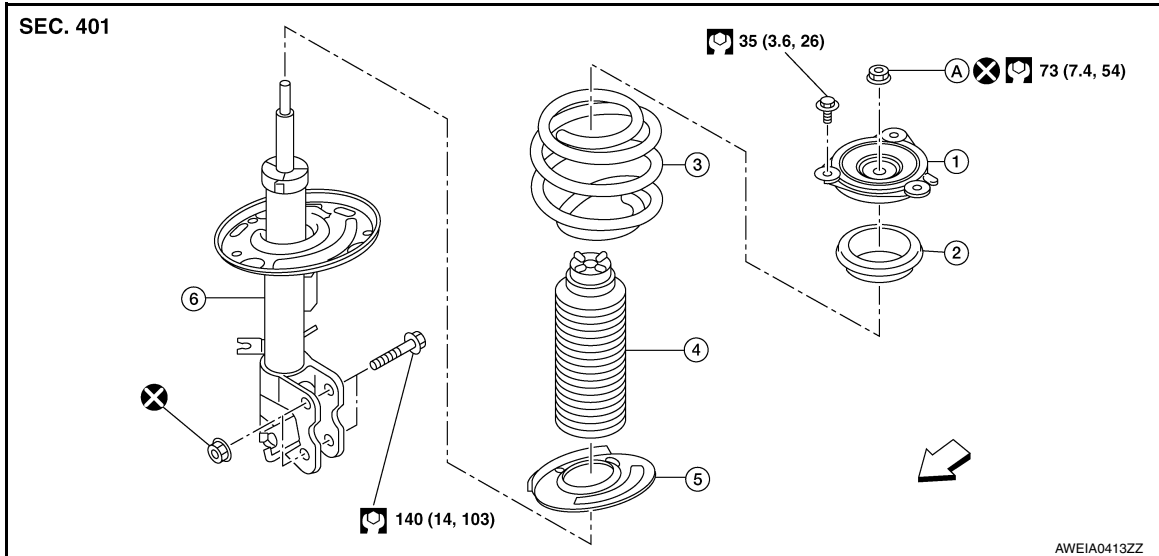

- | | | |
|--------------------------|----------------------|----------------------|
| 1. Strut mount insulator | 2. Upper rubber seat | 3. Front coil spring |
| 4. Bound bumper | 5. Lower rubber seat | 6. Strut |
| A. Piston rod lock nut | ↔ Front | |

Disassembly and Assembly

INFOID:000000011935668

DISASSEMBLY

CAUTION:

Do not damage piston rod when removing components from front coil spring and strut.

1. Install Tool (A) to front coil spring and strut.

CAUTION:

When installing Tool (A), wrap a shop cloth around front coil spring and strut to protect parts from damage.

Tool number : ST35652000 (-)

2. Secure Tool (A) in a vise.

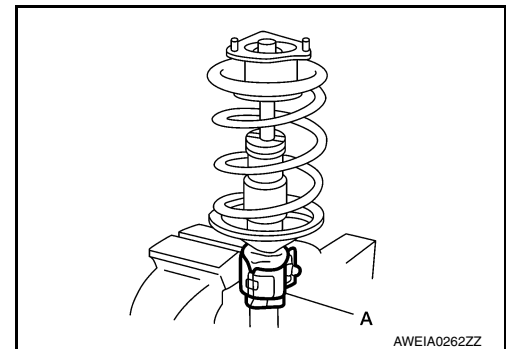

3. Install Tool to strut rod.

Tool number : — (J-49029)

4. Slightly loosen piston rod lock nut.

WARNING:

Do not remove piston rod lock nut completely. If it is removed completely, front coil spring can jump out and may cause serious damage or injury.

FRONT COIL SPRING AND STRUT

< UNIT DISASSEMBLY AND ASSEMBLY >

5. Compress front coil spring using suitable tool (A).

WARNING:

Make sure that pawls of suitable tool are firmly hooked on front coil spring. Suitable tool must be tightened alternately so as not to tilt front coil spring.

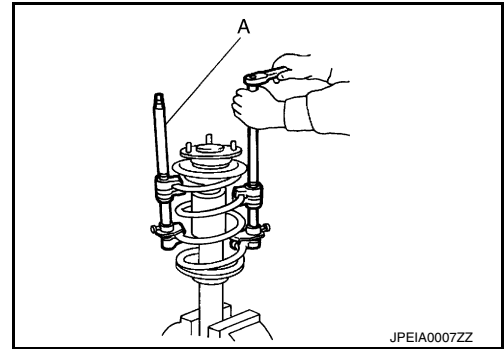

6. Make sure front coil spring is free between strut mount insulator and lower rubber seat.
7. Hold piston rod and remove piston rod lock nut.
8. Remove strut mount insulator, strut mount bearing, and bound bumper from strut.
9. Gradually release suitable tool and remove front coil spring.

CAUTION:

Release suitable tool while making sure position of suitable tool on front coil spring does not move.

10. Remove lower rubber seat.

INSPECTION AFTER DISASSEMBLY

Strut

- Check strut for deformation, cracks, and damage. Replace strut if necessary.
- Check piston rod for damage, uneven wear, and distortion. Replace strut if necessary.
- Check welded and sealed areas for oil leaks. Replace strut if necessary.

Insulator and Rubber Parts

Check strut mount insulator for cracks. Check rubber parts for wear. Replace parts if necessary.

Front Coil Spring

Check front coil spring for cracks, wear, and damage. Replace front coil spring if necessary.

ASSEMBLY

CAUTION:

Do not damage piston rod when installing components to front coil spring and strut.

1. Install lower rubber seat to strut. Make sure that pin (A) on lower rubber seat is positioned into hole (B) on strut.

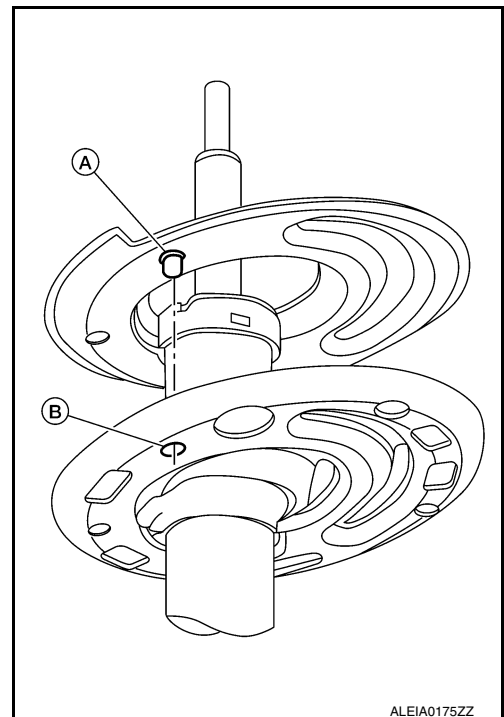

FRONT COIL SPRING AND STRUT

< UNIT DISASSEMBLY AND ASSEMBLY >

2. Compress front coil spring using suitable tool.

WARNING:

Make sure that pawls of suitable tool are firmly hooked on front coil spring. Suitable tool must be tightened alternately so as not to tilt front coil spring.

3. Align lower end of front coil spring (1) with lower rubber seat (2) as shown.

Maximum Gap (A) : 5 mm (0.2 in)

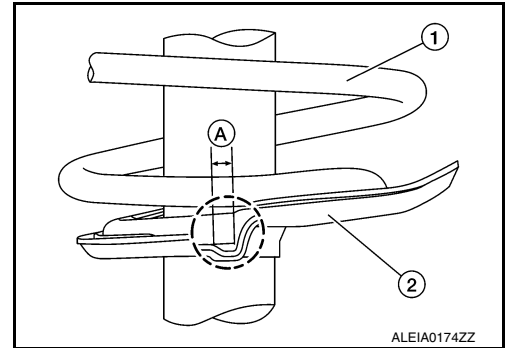

4. Connect bound bumper to strut mount bearing.

CAUTION:

- Be sure to install bound bumper to strut mount bearing securely.
- When installing bound bumper, use soapy water. Do not use machine oil or other lubricants.

5. Install strut mount bearing and strut mount insulator.

6. Temporarily install piston rod lock nut.

CAUTION:

Do not reuse piston rod lock nut.

7. Be sure that tab (A) on strut mount insulator is positioned on out-board side of vehicle.

← : Front

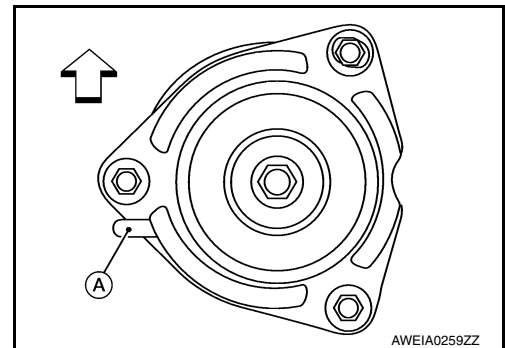

8. Gradually release suitable tool (A) and remove suitable tool from front coil spring.

CAUTION:

Release suitable tool while making sure position of suitable tool on front coil spring does not move.

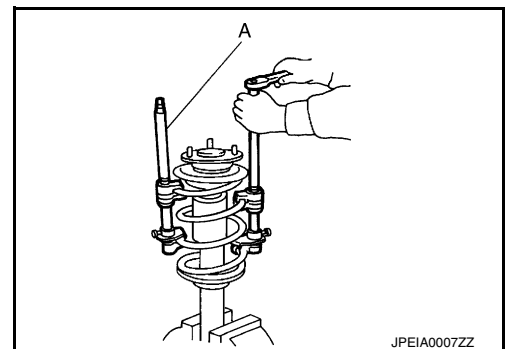

9. Tighten piston rod lock nut to specified torque. Refer to [FSU-19. "Exploded View"](#).

10. Remove Tool from strut rod.

Tool number : — (J-49029)

FRONT COIL SPRING AND STRUT

< UNIT DISASSEMBLY AND ASSEMBLY >

11. Remove Tool (A) from vise.
12. Remove Tool (A) from front coil spring and strut.

Tool number : ST35652000 (-)

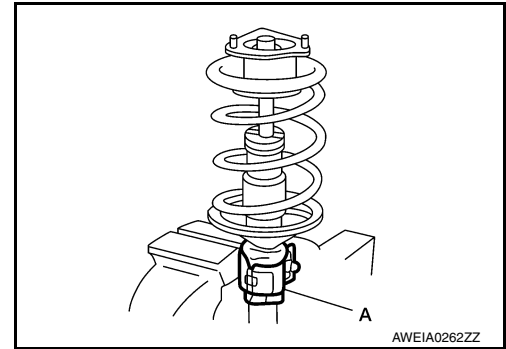

13. After replacing strut, always follow disposal procedure to discard old strut. Refer to [FSU-11, "Disposal"](#).

SERVICE DATA AND SPECIFICATIONS (SDS)

< SERVICE DATA AND SPECIFICATIONS (SDS)

SERVICE DATA AND SPECIFICATIONS (SDS)

SERVICE DATA AND SPECIFICATIONS (SDS)

Wheel Alignment (Unladen*)

INFOID:0000000011935670

UNITED STATES & CANADA

Tire size		P245/45R18	P245/40R19
Camber Degree minute (Decimal degree)	Minimum	-1° 08' (-1.14°)	
	Nominal	-0° 23' (-0.39°)	
	Maximum	0° 22' (0.36°)	
	(LH) and (RH) difference	0° 00' ± 0° 33' (0.00°± 0.55°)	
Caster Degree minute (Decimal degree)	Minimum	4° 05' (4.08°)	4° 10' (4.16°)
	Nominal	4° 50' (4.83°)	4° 55' (4.91°)
	Maximum	5° 35' (5.58°)	5° 40' (5.66°)
	(LH) and (RH) difference	0° 00' ± 0° 30' (0.00°± 0.50°)	
Kingpin inclination Degree minute (Decimal degree)		14° 25' (14.42°)	

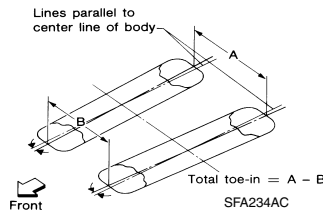

Total toe-in	Distance (A - B)	Minimum	Out 1.2 mm (Out 0.047 in)
		Nominal	In 0.8 mm (In 0.031 in)
		Maximum	In 2.8 mm (In 0.110 in)
	Angle (LH and RH) Degree minute (Decimal degree)	Minimum	Out 0° 07' (Out 0.11°)
		Nominal	In 0° 04' (In 0.07°)
		Maximum	In 0° 15' (In 0.25°)

*: Fuel, engine coolant, and lubricants are full. Spare tire, jack, hand tools, and mats are in designated positions.

MEXICO

Camber Degree minute (Decimal degree)	Minimum	-1° 01' (-1.01°)
	Nominal	-0° 16' (-0.26°)
	Maximum	0° 29' (0.49°)
	(LH) and (RH) difference	0°00' ± 0°33' (0.00°± 0.55°)
Caster Degree minute (Decimal degree)	Minimum	3° 45' (3.75°)
	Nominal	4° 30' (4.50°)
	Maximum	5° 15' (5.25°)
	(LH) and (RH) difference	0° 00' ± 0° 30' (0.00°± 0.50°)
Kingpin inclination Degree minute (Decimal degree)		14° 10' (14.17°)

SERVICE DATA AND SPECIFICATIONS (SDS)

< SERVICE DATA AND SPECIFICATIONS (SDS)

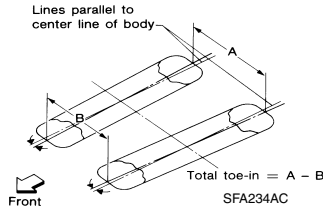

Total toe-in	Distance (A - B)	Minimum	Out 0.9 mm (Out 0.035 in)
		Nominal	In 1.1 mm (In 0.043 in)
		Maximum	In 3.1 mm (In 0.122 in)
	Angle (LH and RH) Degree minute (Decimal degree)	Minimum	Out 0° 05' (Out 0.09°)
		Nominal	In 0° 05' (In 0.09°)
		Maximum	In 0° 16' (In 0.27°)

*: Fuel, engine coolant, and lubricants are full. Spare tire, jack, hand tools, and mats are in designated positions.

Ball Joint

INFOID:0000000011262290

Item	Standard
Swinging torque	0.5 – 4.9 N·m (0.05 – 0.50 kg-m, 4 – 43 in-lb)
Rotating torque	0.5 – 4.9 N·m (0.05 – 0.50 kg-m, 4 – 43 in-lb)
Axial end play	0.1 mm (0.004 in)

Wheelarch Height (Unladen*1)

INFOID:0000000011935672

UNITED STATES & CANADA

Unit: mm (in)

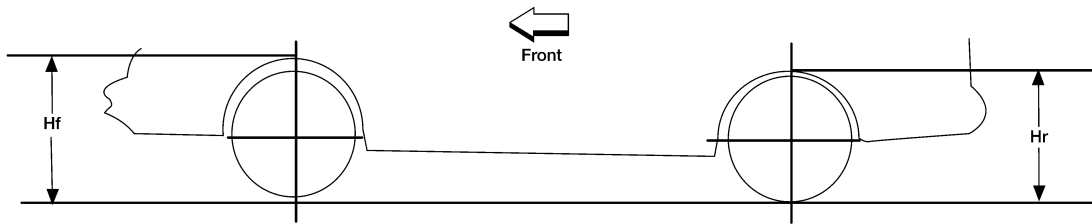

LEIA0085E

Tire size	P245/45R18	P245/40R19
Front (Hf)	708 (27.87)	704 (27.72)
Rear (Hr)	719 (28.31)	712 (28.03)

*1: Fuel, engine coolant, and lubricants are full. Spare tire, jack, hand tools, and mats are in designated positions.

MEXICO

SERVICE DATA AND SPECIFICATIONS (SDS)

< SERVICE DATA AND SPECIFICATIONS (SDS)

Unit: mm (in)

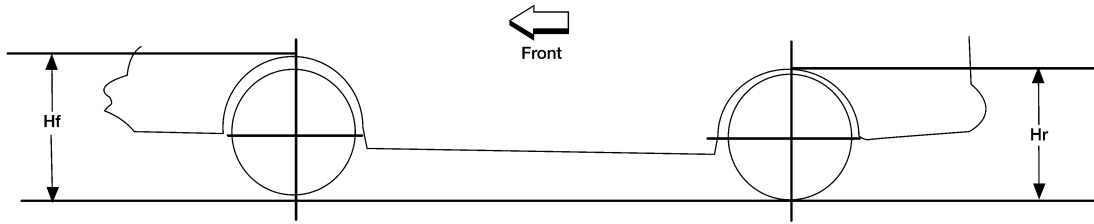

LEIA0085E

Tire size	P245/45R18	P245/40R19
Front (Hf)	717 (28.23)	715 (28.15)
Rear (Hr)	739 (29.09)	736 (28.98)

*1: Fuel, engine coolant, and lubricants are full. Spare tire, jack, hand tools, and mats are in designated positions.

A
B
C
D
F
G
H
I
J
K
L
M
N
O
P

FSU